



恒忻企業股份有限公司(EASY MAGNET CORP.)

SPECIFICATION FOR APPROVAL

CUSTOMER	:	
PART NO.	:	
REV. NO.	:	
DESCRIPTION	:	Wire Wound Chip Inductor
EMC NO.	:	NC SERIES
REV. NO.	:	1.0
DOCUMENT NO.	:	
ISSUE DATE	:	2007. 01. 24

CUSTOMER SIGNATURE		
APPROVED	CHECKED	INSPECTED

CHINA (DONG GUAN) FACTORY:
 No.8 INDUSTRIAL NORTH WAY,178
 INDUSTRIAL AREA,ZUFOLING ADMINISTRIVE,
 TANGXIA,DONG GUAN,KWANG TUNG
 TEL:86-769-7915567~9
 FAX:86-769-7915566

TAIWAN OFFICE:
 12F-7,No.79,SEC.1,HSIN TAI WU RD.
 HSI-CHIN,TAIPEI HSIEN,TAIWAN
 TEL:886-2-2698-9699
 FAX:886-2-2698-9399
<http://www.easymagnet.com.tw>

CHINA (SU ZHOU) FACTORY:
 No.2088 PANGJING ROAD,ECONOMIC
 DEVELOPMENT ZONE,WUJIANG CITY,
 JIANGSU
 TEL:86-512-63430335
 FAX:86-512-63430368

APPROVED	CHECKED	PREPARED
FRANK	LINDA	彭繼湘

SAMPLE MADE IN CHINA
*Samples meet RoHS and
 Lead-free requirement*



WIRE WOUND CHIP INDUCTORS NC SERIES

Introductions

The NC series are wire wound chip inductors widely used in the communication applications such as cellular phones, cable modem, ADSL, repeaters, Bluetooth, and other electronic devices. The wire wound inductors advance in higher self resonate frequency, better Q factor, and much more stable performance. Precious tolerance of 2% is available.

Features

- * Operating temperature -40 to +125 °C for ceramic series and -40 to +85°C for ferrite series.
- * Excellent solderability and resistance to soldering heat .
- * Suitable for reflow soldering..
- * High reliability and easy surface mount assembly.
- * Wide range of inductance values are available for flexible needs.
- * Consisting of 0402 ~ 1210 size.

Part Number Code

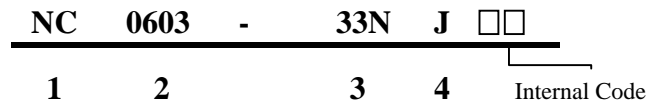

1 Product Type

2 Chip Dimension

Size (inch) mm	Length (L) (inch) mm	Width (W) (inch) mm	Thickness (T) (inch) mm	Terminal (S) (inch) mm
NC 0402	(0.039 ± 0.004) 1.00 ± 0.10	(0.022 ± 0.004) 0.55 ± 0.10	(0.020 ± 0.004) 0.50 ± 0.10	(0.008 ± 0.004) 0.20 ± 0.10
NC 0603	(0.063 ± 0.008) 1.60 ± 0.20	(0.041 ± 0.008) 1.05 ± 0.20	(0.041 ± 0.008) 1.05 ± 0.20	(0.014 ± 0.004) 0.35 ± 0.10
NC 0805	(0.080 ± 0.008) 2.00 ± 0.20	(0.050 ± 0.008) 1.25 ± 0.20	(0.048 ± 0.008) 1.20 ± 0.20	(0.016 ± 0.004) 0.40 ± 0.10
NC 1008	(0.098 ± 0.008) 2.50 ± 0.20	(0.080 ± 0.008) 2.00 ± 0.20	(0.063 ± 0.008) 1.60 ± 0.20	(0.020 ± 0.004) 0.50 ± 0.10
NC 1210	(0.126 ± 0.008) 3.20 ± 0.20	(0.098 ± 0.008) 2.50 ± 0.20	(0.087 ± 0.008) 2.20 ± 0.20	(0.020 ± 0.004) 0.50 ± 0.10

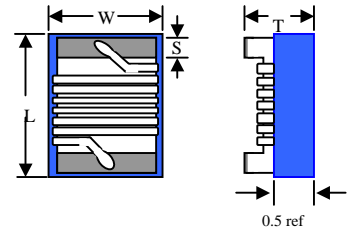

3 Inductance Value

3N3 = 3.3 nH	3R3 = 3.3 uH	102 = 1000 uH
33N = 33 nH	330 = 33 uH	
R33 = 330 nH	101 = 100 uH	

4 Tolerance

B = ± 0.20 nH	G = ± 2 %	K = ± 10 %
S = ± 0.3 nH	J = ± 5 %	

Specification

Part No.	Inductance ¹ (nH)	Percent Tolerance	Q ²		S.R.F. ³ Min (MHz)	RDC ⁴ Max (Ω)	IDC ⁵ Max (mA)
			Min	Typical			
			@900MHz				
NC 0402 - 1N0 □□□	1.0 @ 250 MHZ	B, S	13	26	6000	0.045	1360
NC 0402 - 1N9 □□□	1.9 @ 250 MHZ	B, S	16	29	6000	0.070	1040
NC 0402 - 2N0 □□□	2.0 @ 250 MHZ	B, S	16	30	6000	0.070	1040
NC 0402 - 2N2 □□□	2.2 @ 250 MHZ	B, S	18	32	6000	0.070	960
NC 0402 - 2N4 □□□	2.4 @ 250 MHZ	B, S	16	35	6000	0.068	790
NC 0402 - 2N7 □□□	2.7 @ 250 MHZ	B, S	16	31	6000	0.120	640
NC 0402 - 3N3 □□□	3.3 @ 250 MHZ	K, J, B	20	41	6000	0.066	840
NC 0402 - 3N6 □□□	3.6 @ 250 MHZ	K, J, B	20	43	6000	0.066	840
NC 0402 - 3N9 □□□	3.9 @ 250 MHZ	K, J, B	20	41	5800	0.066	840
NC 0402 - 4N3 □□□	4.3 @ 250 MHZ	K, J, B	18	45	6000	0.091	700
NC 0402 - 4N7 □□□	4.7 @ 250 MHZ	K, J, B	15	45	4775	0.130	640
NC 0402 - 5N1 □□□	5.1 @ 250 MHZ	K, J, B	23	49	5800	0.083	800
NC 0402 - 5N6 □□□	5.6 @ 250 MHZ	K, J, B	23	46	5800	0.083	760
NC 0402 - 6N2 □□□	6.2 @ 250 MHZ	K, J, B	23	49	5800	0.083	760
NC 0402 - 6N8 □□□	6.8 @ 250 MHZ	K, J, B	20	50	4800	0.083	680
NC 0402 - 7N5 □□□	7.5 @ 250 MHZ	K, J, B	25	50	5800	0.104	680
NC 0402 - 8N2 □□□	8.2 @ 250 MHZ	K, J, B	25	49	4400	0.104	680
NC 0402 - 8N7 □□□	8.7 @ 250 MHZ	K, J, B	18	50	4100	0.200	480
NC 0402 - 9N0 □□□	9.0 @ 250 MHZ	K, J, B	25	49	4160	0.104	680
NC 0402 - 9N5 □□□	9.5 @ 250 MHZ	K, J, B	18	45	4000	0.200	680
NC 0402 - 10N □□□	10 @ 250 MHZ	K, J, G	23	47	3900	0.195	480
NC 0402 - 11N □□□	11 @ 250 MHZ	K, J, G	26	56	3680	0.120	640
NC 0402 - 12N □□□	12 @ 250 MHZ	K, J, G	26	51	3600	0.120	640
NC 0402 - 13N □□□	13 @ 250 MHZ	K, J, G	24	54	3450	0.210	560
NC 0402 - 15N □□□	15 @ 250 MHZ	K, J, G	26	54	3280	0.172	560
NC 0402 - 16N □□□	16 @ 250 MHZ	K, J, G	24	54	3100	0.220	560
NC 0402 - 18N □□□	18 @ 250 MHZ	K, J, G	25	52	3100	0.230	420
NC 0402 - 19N □□□	19 @ 250 MHZ	K, J, G	26	50	3040	0.202	480
NC 0402 - 20N □□□	20 @ 250 MHZ	K, J, G	25	51	3000	0.250	420
NC 0402 - 22N □□□	22 @ 250 MHZ	K, J, G	25	52	2800	0.300	400
NC 0402 - 23N □□□	23 @ 250 MHZ	K, J, G	26	53	2720	0.214	400
NC 0402 - 24N □□□	24 @ 250 MHZ	K, J, G	25	51	2700	0.300	400
NC 0402 - 27N □□□	27 @ 250 MHZ	K, J, G	26	48	2480	0.298	400
NC 0402 - 30N □□□	30 @ 250 MHZ	K, J, G	25	46	2350	0.300	400
NC 0402 - 33N □□□	33 @ 250 MHZ	K, J, G	24	48	2350	0.350	400
NC 0402 - 36N □□□	36 @ 250 MHZ	K, J, G	26	48	2320	0.403	320
NC 0402 - 39N □□□	39 @ 250 MHZ	K, J, G	25	45	2100	0.550	320
NC 0402 - 40N □□□	40 @ 250 MHZ	K, J, G	26	48	2240	0.438	320
NC 0402 - 43N □□□	43 @ 250 MHZ	K, J, G	25	46	2030	0.810	100
NC 0402 - 47N □□□	47 @ 200 MHZ	K, J, G	26	46	2100	0.830	100
NC 0402 - 51N □□□	51 @ 200 MHZ	K, J	25	40	1750	0.820	100
NC 0402 - 56N □□□	56 @ 200 MHZ	K, J	22	42	1760	0.970	100
NC 0402 - 68N □□□	68 @ 200 MHZ	K, J	22	36	1620	1.120	100
NC 0402 - 82N □□□	82 @ 150 MHZ	K, J	20	33	1500	1.250	100
NC 0402 - R10 □□□	100 @ 150 MHZ	K, J	20	30	1300	2.520	100
NC 0402 - R12 □□□	120 @ 150 MHZ	K, J	20	29	1100	2.660	100

1. Inductance is measured in HP-4287A RF LCR meter with HP-16193 fixture.

2. Q is measured in HP-4287A RF LCR meter with HP-16193 fixture.

3. SRF is measured in ENA E5071B network analyzer

4. RDC is measured in HP-4338B milliohmeter.

5. For 15 °C Rise.

6. Unit weight = 0.0008g (for ref.)

Specification

Part No.	Inductance ¹ (nH)	Percent Tolerance	Q ²		S.R.F. ³	RDC ⁴	IDC ⁵
			Min	Typical	Min	Max	Max
			@900MHZ		(MHz)	(Ω)	(mA)
NC 0603 - 2N0 □□□	2.0 @ 250 MHZ	B, S	16	31	6900	0.08	700
NC 0603 - 3N9 □□□	3.9 @ 250 MHZ	B, S	22	51	6900	0.08	700
NC 0603 - 4N7 □□□	4.7 @ 250 MHZ	B, S	20	47	5800	0.13	700
NC 0603 - 6N8 □□□	6.8 @ 250 MHZ	K, J, B	30	63	5800	0.11	700
NC 0603 - 8N2 □□□	8.2 @ 250 MHZ	K, J, B	30	72	4600	0.10	700
NC 0603 - 10N □□□	10 @ 250 MHZ	K, J, G	30	66	4800	0.13	700
NC 0603 - 12N □□□	12 @ 250 MHZ	K, J, G	35	72	4000	0.13	700
NC 0603 - 15N □□□	15 @ 250 MHZ	K, J, G	35	68	4000	0.17	700
NC 0603 - 18N □□□	18 @ 250 MHZ	K, J, G	38	77	3100	0.17	700
NC 0603 - 22N □□□	22 @ 250 MHZ	K, J, G	38	70	3000	0.22	700
NC 0603 - 27N □□□	27 @ 250 MHZ	K, J, G	40	75	2800	0.22	600
NC 0603 - 33N □□□	33 @ 250 MHZ	K, J, G	43	78	2300	0.22	600
NC 0603 - 39N □□□	39 @ 250 MHZ	K, J, G	43	66	2200	0.25	600
NC 0603 - 47N □□□	47 @ 200 MHZ	K, J, G	40	65	2000	0.28	600
NC 0603 - 56N □□□	56 @ 200 MHZ	K, J, G	40	66	1900	0.31	600
NC 0603 - 68N □□□	68 @ 200 MHZ	K, J, G	40	57	1700	0.34	600
NC 0603 - 72N □□□	72 @ 150 MHZ	K, J, G	35	60	1700	0.49	400
NC 0603 - 82N □□□	82 @ 150 MHZ	K, J, G	35	58	1700	0.54	400
NC 0603 - R10 □□□	100 @ 150 MHZ	K, J, G	35	51	1400	0.63	400
NC 0603 - R12 □□□	120 @ 150 MHZ	K, J, G	35	45	1300	0.65	300
NC 0603 - R15 □□□	150 @ 150 MHZ	K, J, G	35	33	1000	0.92	280
NC 0603 - R18 □□□	180 @ 100 MHZ	K, J, G	30	26	1000	1.25	240
NC 0603 - R22 □□□	220 @ 100 MHZ	K, J, G	30	23	1000	1.70	200
NC 0603 - R27 □□□	270 @ 100 MHZ	K, J, G	30	10	1000	1.80	170

1. Inductance is measured in HP-4287A RF LCR meter with HP-16193 fixture.

2. Q is measured in HP-4287A RF LCR meter with HP-16193 fixture.

3. SRF is measured in ENA E5071B network analyzer

4. RDC is measured in HP-4338B milliohmeter.

5. For 15 °C Rise.

6. Unit weight = 0.0049g (for ref.)

Specification

Part No.	Inductance ¹ (nH)	Percent Tolerance	Q ² Min	S.R.F. ³		RDC ⁴ Max (Ω)	IDC ⁵ Max (mA)
				Min (MHz)	Max		
NC 0805 - 2N2□□□	2.2 @ 250 MHZ	B, S	50 @ 1000 MHZ	6000		0.06	800
NC 0805 - 2N7□□□	2.7 @ 250 MHZ	B, S	35 @ 1000 MHZ	6000		0.08	800
NC 0805 - 3N3□□□	3.3 @ 250 MHZ	B, S	60 @ 1000 MHZ	6000		0.08	800
NC 0805 - 3N9□□□	3.9 @ 250 MHZ	B, S	60 @ 1000 MHZ	6000		0.06	600
NC 0805 - 4N7□□□	4.7 @ 250 MHZ	B, S	60 @ 1000 MHZ	5800		0.06	600
NC 0805 - 5N6□□□	5.6 @ 250 MHZ	K, J, B	60 @ 1000 MHZ	5800		0.08	600
NC 0805 - 6N8□□□	6.8 @ 250 MHZ	K, J, B	60 @ 1000 MHZ	5500		0.06	600
NC 0805 - 8N2□□□	8.2 @ 250 MHZ	K, J, B	60 @ 1000 MHZ	5500		0.06	600
NC 0805 - 10N□□□	10 @ 250 MHZ	K, J, G	60 @ 500 MHZ	4800		0.08	600
NC 0805 - 12N□□□	12 @ 250 MHZ	K, J, G	60 @ 500 MHZ	4100		0.08	600
NC 0805 - 15N□□□	15 @ 250 MHZ	K, J, G	60 @ 500 MHZ	3600		0.08	600
NC 0805 - 18N□□□	18 @ 250 MHZ	K, J, G	60 @ 500 MHZ	3400		0.08	600
NC 0805 - 22N□□□	22 @ 250 MHZ	K, J, G	60 @ 500 MHZ	3300		0.10	600
NC 0805 - 27N□□□	27 @ 250 MHZ	K, J, G	60 @ 500 MHZ	2600		0.12	600
NC 0805 - 33N□□□	33 @ 250 MHZ	K, J, G	60 @ 500 MHZ	2400		0.15	500
NC 0805 - 39N□□□	39 @ 250 MHZ	K, J, G	60 @ 500 MHZ	2100		0.18	500
NC 0805 - 47N□□□	47 @ 200 MHZ	K, J, G	60 @ 500 MHZ	1700		0.15	500
NC 0805 - 56N□□□	56 @ 200 MHZ	K, J, G	60 @ 500 MHZ	1600		0.25	500
NC 0805 - 68N□□□	68 @ 200 MHZ	K, J, G	60 @ 500 MHZ	1450		0.27	500
NC 0805 - 82N□□□	82 @ 150 MHZ	K, J, G	60 @ 500 MHZ	1350		0.32	500
NC 0805 - R10□□□	100 @ 150 MHZ	K, J, G	60 @ 500 MHZ	1200		0.43	500
NC 0805 - R12□□□	120 @ 150 MHZ	K, J, G	50 @ 250 MHZ	1100		0.48	500
NC 0805 - R15□□□	150 @ 100 MHZ	K, J, G	50 @ 250 MHZ	950		0.56	400
NC 0805 - R18□□□	180 @ 100 MHZ	K, J, G	50 @ 250 MHZ	900		0.78	400
NC 0805 - R22□□□	220 @ 100 MHZ	K, J, G	50 @ 250 MHZ	860		1.00	400
NC 0805 - R27□□□	270 @ 100 MHZ	K, J, G	45 @ 250 MHZ	850		1.46	350
NC 0805 - R33□□□	330 @ 100 MHZ	K, J, G	45 @ 250 MHZ	800		1.65	300
NC 0805 - R39□□□	390 @ 100 MHZ	K, J, G	45 @ 250 MHZ	780		2.20	210

1. Inductance is measured in HP-4287A RF LCR meter with HP-16193 fixture.

2. Q is measured in HP-4287A RF LCR meter with HP-16193 fixture.

3. SRF is measured in ENA E5071B network analyzer

4. RDC is measured in HP-4338B millohmmeter.

5. For 15 °C Rise.

6. Unit weight = 0.0084g (for ref.)

Specification

Part No.	Inductance ¹ (nH)	Percent Tolerance	Q ² Min	S.R.F. ³	RDC ⁴	IDC ⁵
				Min Max (MHz)	Max (Ω)	Max (mA)
NC 1008 - 3N3 □□□	3.3 @ 100 MHZ	B, S	50 @ 1000 MHZ	6000	0.06	1000
NC 1008 - 6N8 □□□	6.8 @ 100 MHZ	K, J, B	50 @ 1000 MHZ	5500	0.06	1000
NC 1008 - 8N2 □□□	8.2 @ 100 MHZ	K, J, B	50 @ 1000 MHZ	5500	0.06	1000
NC 1008 - 10N □□□	10 @ 100 MHZ	K, J, G	50 @ 1000 MHZ	4300	0.08	1000
NC 1008 - 12N □□□	12 @ 100 MHZ	K, J, G	60 @ 500 MHZ	3600	0.08	1000
NC 1008 - 15N □□□	15 @ 100 MHZ	K, J, G	60 @ 500 MHZ	2700	0.08	1000
NC 1008 - 18N □□□	18 @ 100 MHZ	K, J, G	60 @ 350 MHZ	2700	0.10	1000
NC 1008 - 22N □□□	22 @ 100 MHZ	K, J, G	60 @ 350 MHZ	2500	0.10	1000
NC 1008 - 27N □□□	27 @ 100 MHZ	K, J, G	60 @ 350 MHZ	1800	0.10	1000
NC 1008 - 33N □□□	33 @ 100 MHZ	K, J, G	60 @ 350 MHZ	1700	0.10	1000
NC 1008 - 39N □□□	39 @ 100 MHZ	K, J, G	60 @ 350 MHZ	1500	0.10	1000
NC 1008 - 47N □□□	47 @ 100 MHZ	K, J, G	60 @ 350 MHZ	1500	0.10	1000
NC 1008 - 56N □□□	56 @ 100 MHZ	K, J, G	60 @ 350 MHZ	1350	0.12	1000
NC 1008 - 68N □□□	68 @ 100 MHZ	K, J, G	60 @ 350 MHZ	1300	0.15	1000
NC 1008 - 82N □□□	82 @ 100 MHZ	K, J, G	60 @ 350 MHZ	1100	0.18	1000
NC 1008 - R10 □□□	100 @ 100 MHZ	K, J, G	60 @ 350 MHZ	1100	0.18	1000
NC 1008 - R12 □□□	120 @ 25 MHZ	K, J, G	45 @ 100 MHZ	950	0.20	800
NC 1008 - R15 □□□	150 @ 25 MHZ	K, J, G	45 @ 100 MHZ	880	0.22	800
NC 1008 - R18 □□□	180 @ 25 MHZ	K, J, G	45 @ 100 MHZ	800	0.33	800
NC 1008 - R22 □□□	220 @ 25 MHZ	K, J, G	45 @ 100 MHZ	730	0.45	800
NC 1008 - R27 □□□	270 @ 25 MHZ	K, J, G	45 @ 100 MHZ	650	0.75	600
NC 1008 - R33 □□□	330 @ 25 MHZ	K, J, G	45 @ 100 MHZ	570	0.90	500
NC 1008 - R39 □□□	390 @ 25 MHZ	K, J, G	45 @ 100 MHZ	530	1.06	470
NC 1008 - R47 □□□	470 @ 25 MHZ	K, J, G	45 @ 100 MHZ	480	1.17	420
NC 1008 - R56 □□□	560 @ 25 MHZ	K, J, G	45 @ 100 MHZ	430	1.50	310
NC 1008 - R68 □□□	680 @ 25 MHZ	K, J, G	45 @ 100 MHZ	380	2.06	230
NC 1008 - R75 □□□	750 @ 25 MHZ	K, J, G	45 @ 100 MHZ	360	2.20	200
NC 1008 - R82 □□□	820 @ 25 MHZ	K, J, G	45 @ 100 MHZ	350	2.30	180
NC 1008 - R91 □□□	910 @ 25 MHZ	K, J, G	45 @ 100 MHZ	330	3.18	150
NC 1008 - 1R0 □□□	1000 @ 25 MHZ	K, J, G	35 @ 50 MHZ	310	3.30	120

1. Inductance is measured in HP-4287A RF LCR meter with HP-16193 fixture.

2. Q is measured in HP-4287A RF LCR meter with HP-16193 fixture.

3. SRF is measured in ENA E5071B network analyzer

4. RDC is measured in HP-4338B milliohmmeter.

5. For 15 °C Rise.

6. Unit weight = 0.025g (for ref.)

Specification

Part No.	Inductance ¹ (nH)	Percent Tolerance	Q ² Min	S.R.F. ³	RDC ⁴	IDC ⁵
				Min (MHz)	Max (Ω)	Max (mA)
NC 1210 - 4N7 □□□	4.7 @ 100 MHZ	B, S	50 @ 1000 MHZ	6000	0.06	1000
NC 1210 - 5N6 □□□	5.6 @ 100 MHZ	K, J, B	50 @ 1000 MHZ	5500	0.08	1000
NC 1210 - 10N □□□	10 @ 100 MHZ	K, J, G	60 @ 500 MHZ	4000	0.06	1000
NC 1210 - 12N □□□	12 @ 100 MHZ	K, J, G	60 @ 500 MHZ	3400	0.06	1000
NC 1210 - 15N □□□	15 @ 100 MHZ	K, J, G	60 @ 500 MHZ	3200	0.06	1000
NC 1210 - 18N □□□	18 @ 100 MHZ	K, J, G	60 @ 300 MHZ	2800	0.06	1000
NC 1210 - 22N □□□	22 @ 100 MHZ	K, J, G	60 @ 300 MHZ	2100	0.08	1000
NC 1210 - 27N □□□	27 @ 100 MHZ	K, J, G	60 @ 300 MHZ	1900	0.08	1000
NC 1210 - 33N □□□	33 @ 100 MHZ	K, J, G	60 @ 300 MHZ	1700	0.08	1000
NC 1210 - 39N □□□	39 @ 100 MHZ	K, J, G	60 @ 300 MHZ	1700	0.08	1000
NC 1210 - 47N □□□	47 @ 100 MHZ	K, J, G	60 @ 300 MHZ	1400	0.08	1000
NC 1210 - 56N □□□	56 @ 100 MHZ	K, J, G	60 @ 300 MHZ	1100	0.10	1000
NC 1210 - 68N □□□	68 @ 100 MHZ	K, J, G	60 @ 300 MHZ	1000	0.10	1000
NC 1210 - 82N □□□	82 @ 100 MHZ	K, J, G	60 @ 300 MHZ	1000	0.10	1000
NC 1210 - R10 □□□	100 @ 100 MHZ	K, J, G	60 @ 300 MHZ	900	0.10	1000
NC 1210 - R12 □□□	120 @ 50 MHZ	K, J, G	60 @ 300 MHZ	900	0.12	800
NC 1210 - R15 □□□	150 @ 50 MHZ	K, J, G	60 @ 300 MHZ	800	0.18	800
NC 1210 - R18 □□□	180 @ 50 MHZ	K, J, G	60 @ 300 MHZ	760	0.21	800
NC 1210 - R22 □□□	220 @ 50 MHZ	K, J, G	60 @ 300 MHZ	660	0.27	800
NC 1210 - R27 □□□	270 @ 50 MHZ	K, J, G	50 @ 300 MHZ	600	0.33	700
NC 1210 - R33 □□□	330 @ 50 MHZ	K, J, G	50 @ 100 MHZ	550	0.37	650
NC 1210 - R39 □□□	390 @ 50 MHZ	K, J, G	50 @ 100 MHZ	500	0.63	600
NC 1210 - R47 □□□	470 @ 50 MHZ	K, J, G	50 @ 100 MHZ	450	0.69	550
NC 1210 - R56 □□□	560 @ 50 MHZ	K, J, G	50 @ 100 MHZ	400	0.90	450
NC 1210 - R68 □□□	680 @ 25 MHZ	K, J, G	50 @ 100 MHZ	380	1.05	400
NC 1210 - R82 □□□	820 @ 25 MHZ	K, J, G	50 @ 100 MHZ	350	1.45	350
NC 1210 - 1R0 □□□	1000 @ 25 MHZ	K, J, G	45 @ 100 MHZ	300	1.90	280
NC 1210 - 1R2 □□□	1200 @ 7.96 MHZ	K, J	45 @ 50 MHZ	300	2.20	250
NC 1210 - 1R5 □□□	1500 @ 7.96 MHZ	K, J	45 @ 50 MHZ	250	2.43	220
NC 1210 - 1R8 □□□	1800 @ 7.96 MHZ	K, J	45 @ 50 MHZ	200	3.36	180
NC 1210 - 2R2 □□□	2200 @ 7.96 MHZ	K, J	45 @ 50 MHZ	200	3.50	150

1. Inductance is measured in HP-4287A RF LCR meter with HP-16193 fixture.

2. Q is measured in HP-4287A RF LCR meter with HP-16193 fixture.

3. SRF is measured in ENA E5071B network analyzer

4. RDC is measured in HP-4338B milliohmmeter.

5. For 15 °C Rise.

6. Unit weight = 0.045g (for ref.)

Packing Quantity

Type	Pcs / Reel
NC0402	10,000
NC0603	3,000
NC0805	2,000
NC1008	2,000
NC1210	2,000

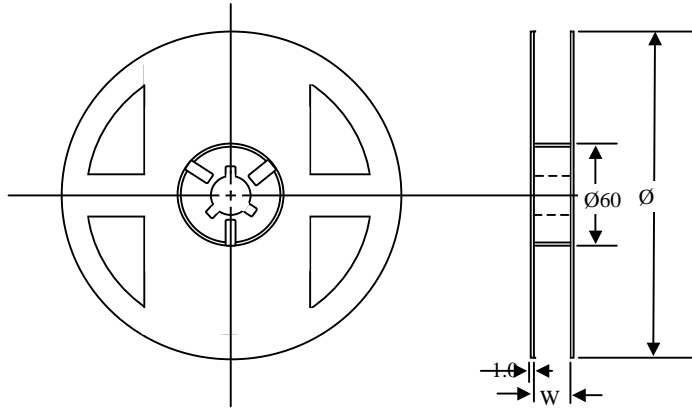

Dimensions (unit: m/m)

Type	Chip Cavity		Insert Pitch F	Tape Thickness		
	A	B		K	T	W
NC0402	0.70	1.20	2.00	-	0.70	8.00
NC0603	1.25	1.80	4.00	1.10	0.20	8.00
NC0805	1.42	2.26	4.00	1.30	0.20	8.00
NC1008	2.23	2.73	4.00	1.80	0.20	8.00
NC1210	2.69	3.56	4.00	2.40	0.20	8.00

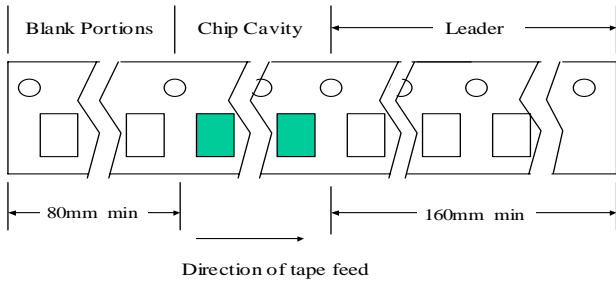
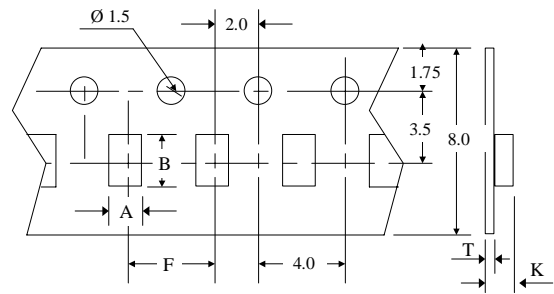

Top Tape Strength

The top tape requires a peel-off force of 0.2 to 0.7N in the direction of the arrow as illustrated below.

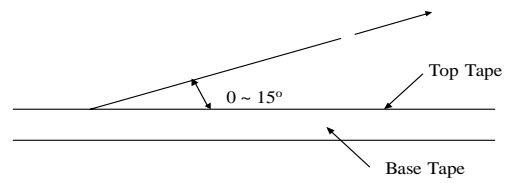

Dimensions (unit : m/m)

TYPE	A	B	C
NC0402	1.20	0.45	0.65
NC0603	1.90	0.65	1.00
NC0805	2.60	0.75	1.30
NC1008	3.00	1.20	2.20
NC1210	4.00	1.70	2.82